

# Barton County Commission Agenda Meeting Minutes

Recorded audio is available on compact disk upon KORA request to the Barton County Clerk's Office, 1400 Main – Room 202, Great Bend, Kansas 67530.

Phone (620) 793-1835 \ Fax (620) 793-1990 \ Email [clerk@bartoncounty.org](mailto:clerk@bartoncounty.org)

Meetings Live Streamed through **Microsoft Teams**® at the following link: <https://bit.ly/40jBIJY>

March 29, 2023

The Board of Barton County Commissioners convened this 29th day of March 2023, at the Barton County Courthouse.

## *Members present:*

Duane Reif, Commissioner, 1<sup>st</sup> District  
Shawn Hutchinson, Commissioner, 3<sup>rd</sup> District, Chairman  
Tricia Schlessiger, Commissioner, 4<sup>th</sup> District  
Donna Zimmerman, Commissioner, 5<sup>th</sup> District  
Bev Schmeidler, County Clerk  
Matt Patzner, County Administrator  
Patrick Hoffman, County Counselor

## *Members absent:*

Barb Esfeld, Commissioner, 2<sup>nd</sup> District, *(Chairman Pro-Tem)*

## **I. OPENING BUSINESS:**

Commissioner Hutchinson called the meeting to order at 9:00 A.M.

Commissioner Zimmerman moved to approve the agenda.  
Commissioner Schlessiger seconded the motion.  
All voted aye. Motion passed.

Commissioner Zimmerman moved to approve the minutes of the March 22, 2023, Regular Meeting.  
Commissioner Reif seconded the motion.  
All voted aye. Motion passed.

## **II. APPROVAL OF APPROPRIATIONS:**

-Bev Schmeidler, County Clerk, will present details. An Accounts Payable Register will be submitted to the Commission for the period of March 15, 2023, and ending March 29, 2023.

Commissioner Schlessiger moved to approve appropriations for the period of March 15, 2023, to March 29, 2023. Authorize the Chairman to sign on behalf of the Commission.  
Commissioner Zimmerman seconded the motion.  
All voted aye. Motion passed.

## **III. OLD BUSINESS:**

-There was no Old Business.

## **IV. NEW BUSINESS:**

### **A. PROCLAMATION 2023-02: Sexual Assault Awareness Month:**

-Kylee Graves, Family Crisis Center Executive Director, will present the Proclamation. April is designated as Sexual Assault Awareness Month to raise public awareness about sexual violence and to educate communities and individuals on how to prevent sexual violence. The Family Crisis Center provides services for sexual assault survivors at no charge and offers educational and professional training for community members and professionals.

Kylee Graves, Family Crisis Center Executive Director, said they had two proclamations this morning. She brought the directors of the programs and introduced Aimee Norris, Domestic & Sexual Violence Director, who read the proclamation.

Commissioner Zimmerman moved to adopt Proclamation 2023-02, Sexual Assault Awareness Month.

# Barton County Commission Agenda Meeting Minutes

Recorded audio is available on compact disk upon KORA request to the Barton County Clerk's Office, 1400 Main – Room 202, Great Bend, Kansas 67530.

Phone (620) 793-1835 \ Fax (620) 793-1990 \ Email [clerk@bartoncounty.org](mailto:clerk@bartoncounty.org)

Meetings Live Streamed through **Microsoft Teams**® at the following link: <https://bit.ly/40jBIJY>

Commissioner Schlessiger seconded the motion.  
All voted aye. Motion passed.

## **B. PROCLAMATION 2023-03: Child Abuse Awareness and Prevention Month:**

-Ms. Graves will present details. The Family Crisis Center requests that a Proclamation be adopted declaring April, 2023, as Child Abuse Awareness and Prevention Month. The Proclamation states that child abuse and neglect can be reduced by making sure families have the support needed to raise children in a healthy environment and that there are dedicated individuals and organizations in Barton County working to counter these problems.

Kylee Graves, Family Crisis Center Executive Director, said they would be having numerous activities coming up and urged everyone to check their Facebook page and the website. Graves introduced Braeley Hammeke, Child Advocacy Center Program Director. Hammeke read the proclamation.

Commissioner Reif to adopt Proclamation 2023-03, Child Abuse Awareness and Prevention Month.  
Commissioner Schlessiger seconded the motion.  
All voted aye. Motion passed.

## **C. COMMISSION: Barton County Façade Improvement Grants:**

-Matt Patzner, County Administrator, will provide details. In 2021, the Commission dedicated \$630,000.00 to the Façade Improvement Project. With \$31,600.12 of that allocation remaining, the Commission directed \$250,00.00 in funding be reserved for the program in 2023. Four prior projects were named from the 2021 applicants. Another 23 applications were received prior to the March 15, 2023, deadline. The Commission will consider award of funding for a portion of the projects in later items.

Matt Patzner, County Administrator, said monies expended on completed projects totaled \$369,390.43, with extended projects estimated at \$229,009.45. The project remainder was \$31,600.12. The commission did not act on four projects that were labeled as alternatives. The commission labeled those as "priority". On February 8, 2023, the Commission approved \$250,000 in funding for Round 2. Applications were solicited until March 15, 2023, with some changes to the program:

The impact zone was expanded to the "eye shot" of the Main Street corridor.

No more than twenty-five percent of the award may be used toward signage. No more than twenty-five percent of the award may be used toward windows. Applicants are encouraged to use more than fifty percent of the award toward visual impact.

## **ITEM D MOVED TO AFTER ITEM I**

## **E. FAÇADE IMPROVEMENT GRANT: Keller Real Estate & Insurance Agency Inc:**

-Kevin Keller will provide details. Keller Real Estate & Insurance Agency Inc. has requested \$20,000.00 in grant funding to improve the building located at 1101 Williams, Great Bend, Kansas. This is a 2021 priority project. The \$48,900.00 match by the applicant equates to 71% of the project.

Kevin Keller, Keller Real Estate & Insurance Agency, Inc., thanked the commissioners for the opportunity to work with the county. Their business has been in operation since 1968 and in the present location since 1980 or 1981. They had updated the interior, but the exterior was looking old and worn. The Façade Improvement Grant was a perfect fit for them. Keller said they were working with Mark Bitter, and he had

# Barton County Commission Agenda Meeting Minutes

Recorded audio is available on compact disk upon KORA request to the Barton County Clerk's Office, 1400 Main – Room 202, Great Bend, Kansas 67530.

Phone (620) 793-1835 \ Fax (620) 793-1990 \ Email [clerk@bartoncounty.org](mailto:clerk@bartoncounty.org)

Meetings Live Streamed through **Microsoft Teams**® at the following link: <https://bit.ly/40jBIJY>

prepared some nice plans for the improvements. Keller said he and his brother were the second generation in the business. Keller's son, Grant, graduated from college and was also working at the business in the insurance department. Keller said the \$20,000.00 from the county would be greatly appreciated.

Commissioner Hutchinson said that in this case, the business owner would be contributing quite a bit more and greatly increasing the value of their property as well as downtown.

Commissioner Schlessiger moved to approve a Façade Improvement Grant for Keller Real Estate & Insurance Agency Inc., for the building located at 1101 Williams, Great Bend, Kansas, in the amount of \$20,000.00. Direct the Commission Chair to sign the Grant Agreement with the Applicant. Direct the County Administrator to encumber the award amount from the Capital Improvement Fund, Building and Fixed Equipment - General Line, 071-00-6305.

Commissioner Zimmerman seconded the motion.

All voted aye. Motion passed.

Keller asked what was needed from him going forward.

Commissioner Hutchinson said once approved for the grant and the work completed, the business owner submits a paid invoice to the county for reimbursement of the approved amount.

Judy Goreham asked if the changes to the program were covered during study sessions.

Commissioner Hutchinson said yes, that was discussed.

## **F. FAÇADE IMPROVEMENT GRANT: Magna-Dry LLC:**

-Todd Clark will provide details. Magna-Dry LLC has requested \$20,000.00 in grant funding to improve the building located at 1724 Main, Great Bend, Kansas. The \$56,069.42 match by the applicant equates to 74% of the project.

Todd Clark, Magna-Dry LLC, said they were working with Mark's Custom Signs. They quoted just under \$19,000.00 to do the front of the building. They would paint it gray, install a blue awning and a neon sign. They were also working with Andy Mingenback as the north side of the building needs some attention. There were some window issues with a quote of approximately \$11,000.00, which they would cover themselves. Some trusses inside needed repairs and Scott's Welding would take care of them. Clark said he appreciated the opportunity to help improve downtown.

Commissioner Zimmerman to approve a Façade Improvement Grant for Magna-Dry LLC, for the building located at 1724 Main, Great Bend, Kansas, in the amount of \$20,000.00. Direct the Commission Chair to sign the Grant Agreement with the Applicant. Direct the County Administrator to encumber the award amount from the Capital Improvement Fund, Building and Fixed Equipment - General Line, 071-00-6305. Commissioner Reif seconded the motion.

All voted aye. Motion passed.

## **G. FAÇADE IMPROVEMENT GRANT: Matthew Gerritzen:**

-Matthew Gerritzen will provide details. Mr. Gerritzen has requested \$20,000.00 in grant funding to improve the building located at 463 S Main, Hoisington, Kansas. This project is proposed for an agricultural business. The \$7,465.85 match by the applicant equates to 27% of the project.

Matthew Gerritzen said his property was south of Hoisington. He appreciated the opportunity to improve the "front door" entering Hoisington. Gerritzen said he had put up a 72' x 120' warehouse structure for the business, Sundown Agri Supply. The building to the north of the new structure will be used for equipment storage and product storage. Gerritzen had already updated the interior of the building and repaired the

# Barton County Commission Agenda Meeting Minutes

Recorded audio is available on compact disk upon KORA request to the Barton County Clerk's Office, 1400 Main – Room 202, Great Bend, Kansas 67530.

Phone (620) 793-1835 \ Fax (620) 793-1990 \ Email [clerk@bartoncounty.org](mailto:clerk@bartoncounty.org)

Meetings Live Streamed through **Microsoft Teams**® at the following link: <https://bit.ly/40jBJY>

windows but it needed a facelift. Gerritzen would like to make the north building a smaller version of the new building for continuity. Gerritzen said they had been working on the property for about 4 years and want to put new doors and increase security to compliment the area.

Commissioner Hutchinson said improvements going into Hoisington goes a long way.

Commissioner Reif said it was a great day to be a commissioner since we can help small businesses.

Commissioner Reif moved to approve a Façade Improvement Grant for Matthew Gerritzen, for the building located at 463 S Main, Hoisington, Kansas, in the amount of \$20,000.00. Direct the Commission Chair to sign the Grant Agreement with the Applicant. Direct the County Administrator to encumber the award amount from the Capital Improvement Fund, Building and Fixed Equipment - General Line, 071-00-6305.

Commissioner Schlessiger seconded the motion.

All voted aye. Motion passed.

## **H. FAÇADE IMPROVEMENT GRANT: Ancient Free & Accepted Masons of Kansas:**

-Greg King and / or Larry Gale will provide details. The Ancient Free & Accepted Masons of Kansas have requested \$17,091.61 in grant funding to improve the building located at 1917 - 17th, Great Bend, Kansas. The \$5,697.21 match by the applicant equates to 25% of the project.

Greg King said Larry Gale was also present and they appreciated the opportunity for the grant. King said they had been in Great Bend for almost 150 years even though people may not know they were here or where the lodge was located. King said they had been in the present building approximately 10 years. They had updated the inside but needed to dress up the outside and do what they could to make the neighborhood look better. King said they want to paint the building gray and install a black awning with a sign facing west so it would be more noticeable.

Commissioner Hutchinson said he had learned a lot in the last 2 years. He had previously thought that non-profits were exempt from paying property taxes. That was not always the case. The Masonic temple in Great Bend was a non-profit that does pay property taxes.

Commissioner Zimmerman moved to approve a Façade Improvement Grant for Ancient Free & Accepted Masons of Kansas, for the building located at 1917 - 17th, Great Bend, Kansas, in the amount of \$17,091.61. Direct the Commission Chair to sign the Grant Agreement with the Applicant. Direct the County Administrator to encumber the award amount from the Capital Improvement Fund, Building and Fixed Equipment - General Line, 071-00-6305.

Commissioner Schlessiger seconded the motion.

All voted aye. Motion passed.

## **I. FAÇADE IMPROVEMENT GRANT: Frederick L Gunn:**

-Frederick L Gunn will provide details. Mr. Gunn has requested \$20,000.00 in grant funding to improve the building located at 107 N Main, Ellinwood, Kansas. This is a 2021 priority project for the building housing Gunn's Antiques & Collectibles. The \$7,397.15 match by the applicant equates to 27% of the project.

Frederick Gunn, Gunn's Antiques & Collectibles, said he had the business for 13 years. Prior to that, he taught school in Ellinwood. Gunn said Quality Glass will be doing glass work, Mark's Custom Signs will install a new awning. He had done some updating inside the building.

Commissioner Schlessiger moved to approve the Façade Improvement Grant for Frederick L Gunn, for the building located at 107 N Main, Ellinwood, Kansas, in the amount of \$20,000.00. Direct the Commission Chair to sign the Grant Agreement with the Applicant. Direct the County Administrator to

# Barton County Commission Agenda Meeting Minutes

Recorded audio is available on compact disk upon KORA request to the Barton County Clerk's Office, 1400 Main – Room 202, Great Bend, Kansas 67530.

Phone (620) 793-1835 \ Fax (620) 793-1990 \ Email [clerk@bartoncounty.org](mailto:clerk@bartoncounty.org)

Meetings Live Streamed through **Microsoft Teams**® at the following link: <https://bit.ly/40jBJY>

encumber the award amount from the Capital Improvement Fund, Building and Fixed Equipment - General Line, 071-00-6305.

Commissioner Reif seconded the motion.

All voted aye. Motion passed.

Commissioner Hutchinson said that Gunn's, Kellers and Doans were round one applicants and round one rules would apply to their projects.

## **D. FAÇADE IMPROVEMENT GRANT: Eric Doan and Donita Frantz:**

-Eric Doan will provide details. Mr. Doan and Donita Frantz have requested \$13,258.50 in grant funding to improve the building located at 2023 Lakin, Great Bend, Kansas. This is a 2021 priority project for the building housing H&R Block / Doan's Outdoor Store. The \$4,411.50 match by the applicant equates to 25% of the project.

Eric Doan said he opened the outdoor retail store at the beginning of COVID. With no need for a waiting area, the building was too big for just tax preparation, so they split the building in half. The east side housed the outdoor store and the west side tax preparation. Their plan was to put in double door entrances and signage to have a separate entrance for each business. They wanted to update the awning and wrap part of the brick in metal to make it attractive for the customers and community.

Commissioner Reif moved to approve a Façade Improvement Grant for Eric Doan and Donita Frantz, for the building located at 2023 Lakin, Great Bend, Kansas, in the amount of \$13,258.50. Direct the Commission Chair to sign the Grant Agreement with the Applicant. Direct the County Administrator to encumber the award amount from the Capital Improvement Fund, Building and Fixed Equipment - General Line, 071-00-6305.

Commissioner Schlessiger seconded the motion.

All voted aye. Motion passed.

Commissioner Hutchinson said the applicants had one year from today to complete the projects.

## **J. RESOLUTION 2023-10: Application for Zoning Amendment for a Described Tract of Land:**

-Judy Goreham, Environmental Manager, will provide details. Environmental Management received a Zoning Amendment Application from Lance Crosby, dba C4 AG Solutions, LLC. The application calls for an amendment to the zoning classification from Agricultural District to Light Manufacturing Service Commercial District on a 2.7 +/- acre portion of a 9.5 +/- acre tract owned by Lance E. and Amy R. Crosby. If approved, Mr. Crosby will use a newly built 60' x 120' building for office and storage for an agricultural seed and chemical products distribution business. The property is located 466 SW 80 Ave, Pawnee Rock, Kansas.

Judy Goreham, Environmental Manager, said the public hearing was held on March 14<sup>th</sup> and there were no issues to keep the Planning Commission from recommending approval. This was the 3<sup>rd</sup> time in 3 months for businesses that were doing the same type of work. This business would be selling agricultural seed and chemical products. Brand new building located between Dundee and Pawnee Rock that allows for plenty of area to receive deliveries of product. Goreham asked the commission to uphold the recommendation from the Planning Commission. Goreham said one of the things she always dealt with was catching people who had not complied with the regulations or finding out about it half way through. Water wells and septic system regulations had been in Barton County for literally decades and was not much of a problem anymore. With the zoning part of it, there was no liability component on the contractor and there seemed to be a disconnect between parties. Goreham said Crosby put in the building and she understood that it was going to be agricultural use only, was not aware that it was going to be a business. She began to get calls about the location at which point she started inquiring about the use. They were able to backtrack and go through the proper channels. She wanted to encourage the public in Barton County to take a minute and make a phone call before beginning a project.

# Barton County Commission Agenda Meeting Minutes

Recorded audio is available on compact disk upon KORA request to the Barton County Clerk's Office, 1400 Main – Room 202, Great Bend, Kansas 67530.

Phone (620) 793-1835 \ Fax (620) 793-1990 \ Email [clerk@bartoncounty.org](mailto:clerk@bartoncounty.org)

Meetings Live Streamed through **Microsoft Teams**® at the following link: <https://bit.ly/40jBJY>

Commissioner Zimmerman said she remembered a township putting up a building without following regulations and all of the man hours spent to make it work. Goreham said that particular case took 4 years to get them into compliance. Goreham added that when meeting with those township officials, she told them they broke every single rule there was and there was a lot of work done for them to keep their building.

Commissioner Zimmerman moved to adopt Resolution 2023-10, Application for Zoning Amendment for a Described Tract of Land.

Commissioner Schlessiger seconded the motion.

All voted aye. Motion passed.

## **K. BOARD APPOINTMENT: Barton County Planning Commission:**

-Ms. Goreham will provide details. The County has sought applicants for the Barton County Planning Commission. The focus of the Planning Commission is to plan for the proper growth and development of Barton County through the enactment of planning and zoning laws for the protection of the public health, safety and welfare. Although all applicants must reside in Barton County, the majority of members must be from the unincorporated area.

Judy Goreham, Environmental Manager, said she had never had as many applications as she had received this time. These were for three year terms with three positions terming every March 31<sup>st</sup>. Whenever she has an existing member reapply, she encourages the commission to reappoint that person. The three that termed this year were Chad Ehrlich, JC Bosch and Earl Moses. Ehrlich and Bosch had reapplied and Goreham asked that they be reappointed. There were four other applicants: Shane Suchy, Junior Welsch, Dr. Dan Witt and Bob Fairbanks. Goreham asked the commission to choose one of them.

Commissioner Reif moved to re-appoint JC Bosch and Chad Ehrlich and to appoint Dr. Dan Witt to the Barton County Planning Commission for uncompensated positions terming March 31, 2026.

Commissioner Zimmerman seconded the motion.

All voted aye. Motion passed.

## **L. COUNTY ENGINEER: Repair of Box Culvert Concrete Damage on SW 110 Avenue South of SW 40 Road:**

-Darren Williams, County Works Director, will provide details. On February 8, 2023, a vehicle left the road and struck a concrete wing on a box culvert and caused substantial damage. L & M Contractors, Inc. submitted a \$8,570.00 quote for repair work. If the work is approved, the County will pursue recovery of the cost through the vehicle owner's insurance or through civil action. The Engineer recommends approval of the quote in order to proceed with stabilizing the shoulder of the road.

Darren Williams, County Works Director, presented details.

Commissioner Zimmerman moved to approve the \$8,570.00 quote from L & M Contractors, Inc. Cost to be paid from the Special Bridge Fund, Professional Service Fees Line, 003-92-5475-92. Any recovered money is to be deposited into the Special Bridge Fund.

Commissioner Reif seconded the motion.

All voted aye. Motion passed.

## **M. CENTRAL KANSAS COMMUNITY CORRECTIONS: Fiscal Year 2023 Unexpended Funding:**

-Tyler Lehmkuhl, Assistant Director, will provide details. The Kansas Department of Corrections will provide Unexpended Funding to agencies in one hundred percent compliance with fiscal and outcome reporting. This has resulted in CKCC being eligible for an additional \$33,459.05 for Fiscal Year 2023

# Barton County Commission Agenda Meeting Minutes

Recorded audio is available on compact disk upon KORA request to the Barton County Clerk's Office, 1400 Main – Room 202, Great Bend, Kansas 67530.

Phone (620) 793-1835 \ Fax (620) 793-1990 \ Email [clerk@bartoncounty.org](mailto:clerk@bartoncounty.org)

Meetings Live Streamed through **Microsoft Teams**® at the following link: <https://bit.ly/40jBJY>

funds. If accepted, it is anticipated that the monies will be used to purchase a replacement copier, computer equipment, office furniture and other regular operational expenditures.

Tyler Lehmkuhl, Central Kansas Community Corrections Assistant Director, presented details and asked for the commission to approve.

Commissioner Zimmerman asked Lehmkuhl what the funds were going to be used for. Lehmkuhl said a replacement copier, computers, scanners and maintenance on vehicles.

Commissioner Schlessiger moved to approve the Fiscal Year 2023 Unexpended Budget Summary in the amount of \$33,459.05. Authorize the Commission Chairman to sign grant forms as needed.

Commissioner Reif seconded the motion.

All voted aye. Motion passed.

## **N. CENTRAL KANSAS COMMUNITY CORRECTIONS: Purchase of a Copier:**

-Mr. Lehmkuhl will provide details. Anticipating the acceptance of the Fiscal Year 2023 Unexpended Funding, Central Kansas Community Corrections requested a quote for a new copier from Office Products, Inc (OPI). The cost of the Canon imageRUNNER ADVANCE DX 6855i is \$10,150.00, which, if approved, will be split with the Court Services Office.

Tyler Lehmkuhl, Central Kansas Community Corrections Assistant Director, presented details.

Commissioner Zimmerman moved to approve the \$10,150.00 purchase of the Canon imageRUNNER ADVANCE DX 6855i from Office Products, Inc (OPI). With each agency paying \$5,075.00 of that cost, payment is to be made from:

CKCC Fund, Office Furniture and Equipment Line, 095-70-6175-32

Court Services Division of District Court, General Fund, Office Furniture and Equipment, 001-16-6175-32

Commissioner Schlessiger seconded the motion.

All voted aye. Motion passed.

## ***No Executive Session Held***

## **O. EXECUTIVE SESSION:**

-Chairman Shawn Hutchinson will present. Any Commissioner may make a motion for the board to recess to executive session at this time as allowed by K.S.A. 75-4319. Any motion must contain the justification for the executive session, the subject matter to be discussed, any individuals in addition to the board who will attend the executive session and the time at which the regular session shall resume.

## **V. ENDING BUSINESS:**

1. Announcements
2. Appointments

## **VI. OTHER BUSINESS:**

Patrick Hoffman – Reno County Commissioners were moving their meetings to Wednesdays beginning in July. Barton County Commissioners may consider moving meetings to Tuesdays. Hoffman appreciated the commissioners working with him to be able to cover both counties.

Larry Gale – Barton County resident for 50 years but only the 2<sup>nd</sup> time he had attended a commission meeting. He asked for consideration to improve the sound system for hearing impaired individuals.

# Barton County Commission Agenda Meeting Minutes

Recorded audio is available on compact disk upon KORA request to the Barton County Clerk's Office, 1400 Main – Room 202, Great Bend, Kansas 67530.

Phone (620) 793-1835 \ Fax (620) 793-1990 \ Email [clerk@bartoncounty.org](mailto:clerk@bartoncounty.org)

Meetings Live Streamed through **Microsoft Teams**® at the following link: <https://bit.ly/40jBJY>

## VII. ADJOURN.

Commissioner Zimmerman moved to adjourn at 10:00 A.M.

Commissioner Reif seconded the motion.

All voted aye. Motion passed.

ATTEST:

  
Bev Schmeidler  
Barton County Clerk

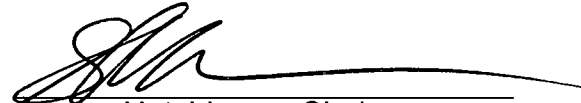
  
Shawn Hutchinson, Chairman



## PROCLAMATION 2023-02

### CHILD ABUSE AWARENESS AND PREVENTION MONTH

**WHEREAS**, preventing child abuse and neglect is a community problem that requires all citizens to be involved; and

**WHEREAS**, child maltreatment occurs when people find themselves in stressful situations without community resources and don't know how to cope; and

**WHEREAS**, child abuse and neglect can be reduced by making sure families have the support they need to raise their children in healthy environment; and

**WHEREAS**, in Barton County, there are dedicated individuals and organizations that work daily to counter the problem of child abuse and neglect and help parents obtain the assistance they need; and

**WHEREAS**, all children deserve freedom from verbal abuse, sexual abuse, emotional abuse and physical abuse and neglect; and

**WHEREAS**, all children deserve to have warm homes, loving hugs, tender care, parents and adults who listen and promote self-esteem, give quality time, provide necessary food shelter, clothing and attention; and

**WHEREAS**, effective child abuse prevention programs succeed because of partnerships created among social service agencies, schools, faith communities, civic organizations, law enforcement agencies and the business community; and

**WHEREAS**, through partnerships and collaborations, the Family Crisis Center, Kansas Children's Service League, Central Kansas Court Appointed Special Advocates, Department for Children and Families, St. Francis Ministries, Child Abuse Prevention and Education, University of Kansas Health Systems – Great Bend Campus SANE program, 20th Judicial District Juvenile Services and law enforcement officers work daily to address child abuse and neglect.

**NOW, THEREFORE, BE IT PROCLAIMED** by the Board of County Commissioners of Barton County, Kansas, that the month of April, 2023, is Child Abuse Awareness and Prevention Month in Barton County; and

**FURTHER**, that the Commission calls upon all citizens, community agencies, faith groups, medical facilities, and businesses to increase participation in efforts to support families, thereby preventing child abuse and strengthening the community.

**Dated** this 29<sup>th</sup> day of March, 2023.

BOARD OF COUNTY COMMISSIONERS



ATTEST:

Bev Schmeidler  
Bev Schmeidler  
County Clerk

Shawn Hutchinson  
Shawn Hutchinson, Chairman

ABSENT.

Barb Esfeld  
Barb Esfeld, Commissioner

Duane A Reif  
Duane A Reif, Commissioner

Tricia Schlessiger  
Tricia Schlessiger, Commissioner

Donna Zimmerman  
Donna Zimmerman, Commissioner

## PROCLAMATION 2023-03

### SEXUAL ASSAULT AWARENESS MONTH

**WHEREAS**, sexual violence is a widespread, preventable, public health problem in Kansas; and

**WHEREAS**, sexual violence is any sexual act that is perpetrated against someone's will, which includes sexual assault, rape, unwanted touching, threatened sexual violence, exhibitionism and verbal sexual harassment; and all types of sexual violence involve victims who do not consent, or who are unable to consent, or who refuse to allow the act; and

**WHEREAS**, one in three women and nearly one in six men experience some form of contact sexual violence in their lifetimes; and

**WHEREAS**, one incident of rape is reported to Kansas law enforcement every 7 hours, 20 minutes, 55 seconds; and over 5,300 people receive services for sexual assault from Kansas victim advocacy organizations each year; and

**WHEREAS**, these statistics do not represent the true prevalence of sexual violence due to underreporting; and sex offenders often targeting people they perceive as vulnerable, less powerful or less credible; and

**WHEREAS**, the offender is known to the victim in the vast majority of cases – 80% in Kansas; and

**WHEREAS**, the effects of sexual violence may be felt directly after or for many months or years later; and confusion, anger, sadness, shame, guilt, helplessness, hopelessness and self-blame are all common reactions to sexual violence; and

**WHEREAS**, the Family Crisis Center, Inc. provides 24/7/365 free and confidential services to victims of sexual violence in Barton, Barber, Comanche, Edwards, Kiowa, Ness, Pawnee, Pratt, Rush and Stafford Counties; and

**WHEREAS**, the Family Crisis Center, Inc. is also available 24/7/365 at 620-792-1885 and the state-wide Kansas Crisis Hotline is available at 1-888-363-2287.

**NOW, THEREFORE, BE IT PROCLAIMED** by the Board of County Commissioners of Barton County, Kansas, that the month of April, 2023, shall be known as SEXUAL ASSAULT AWARENESS MONTH in Barton County; and

**FURTHER**, that the Commission urges citizens to participate in this observance.

**ADOPTED** this 29<sup>th</sup> day of March, 2023.

BOARD OF COUNTY COMMISSIONERS

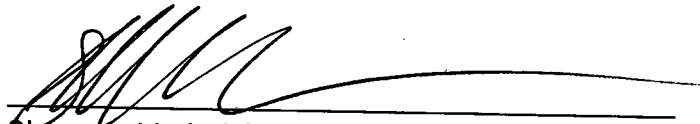
  
Shawn Hutchinson, Chairman

ABSENT

Barb Esfeld, Commissioner

  
Duane A Reif, Commissioner

  
Tricia Schlessiger, Commissioner

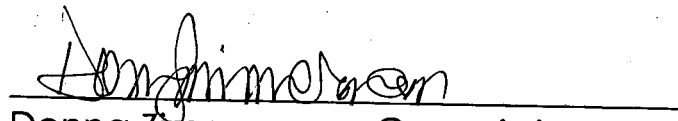
  
Donna Zimmerman, Commissioner

ATTEST:



  
Bev Schmeidler  
County Clerk

**RESOLUTION 2023-10**

**APPLICATION FOR ZONING AMENDMENT FOR A DESCRIBED TRACT OF LAND**

**WHEREAS**, on January 28, 2013, the Barton County Planning Commission recommended to the Board of Barton County Commissioners the adoption of the Barton County Zoning Regulations, including the Official Zoning Map of Barton County, Version II. Said recommendation resulting in the adoption of the current version of the Zoning Regulations; and

**WHEREAS**, on the 14<sup>th</sup> day of March, 2023, the Planning Commission approved a recommendation to the Board of County Commissioners to approve a zoning change request on a certain tract of land; and

**WHEREAS**, the Barton County Planning Commission recommends that:

*A tract of land located within an existing 9.5 +/- acre tract, subject only to the area outlined by the attached map (Attachment A) created by the County Cartographer, consisting of 2.7 +/- acres which is owned by Lance E. & Amy R. Crosby and located south and west of Great Bend, Kansas, with an address of 466 SW 80 Ave, Pawnee Rock, KS 67567 which is further described as being located within the NW 1/4, Section 19, Township 20 South, Range 14 West, Barton County, Kansas;*

Which is currently zoned as Agricultural District shall be designated as Light Manufacturing – Service Commercial District so that Lance Crosby, dba C4 AG Solutions, LLC can use a newly built 60' x 120' building for storage and as an office with the intent to sell agricultural seed and chemical products.

**NOW, THEREFORE**, the Board of County Commissioners of Barton County, Kansas, hereby adopts the recommendation of the Barton County Planning Commission as contained herein; and

**FURTHER**, that the Secretary of the Planning Board is hereby directed to have said revision reflected in the official zoning records of Barton County.

**ADOPTED** this 29<sup>th</sup> day of March, 2023



ATTEST:

*Bev Schmeidler*  
Bev Schmeidler  
County Clerk

APPROVED AS TO FORM:

*Patrick Hoffman*  
Patrick Hoffman,  
County Counselor

BOARD OF COUNTY COMMISSIONERS

*Shawn Hutchinson*  
Shawn Hutchinson, Chair

ABSENT

Barb Esfeld, Commissioner

*Duane A. Reif*  
Duane A. Reif, Commissioner

*Tricia Schlessiger*  
Tricia Schlessiger, Commissioner

*Donna Zimmerman*  
Donna Zimmerman, Commissioner

ATTACHMENT A

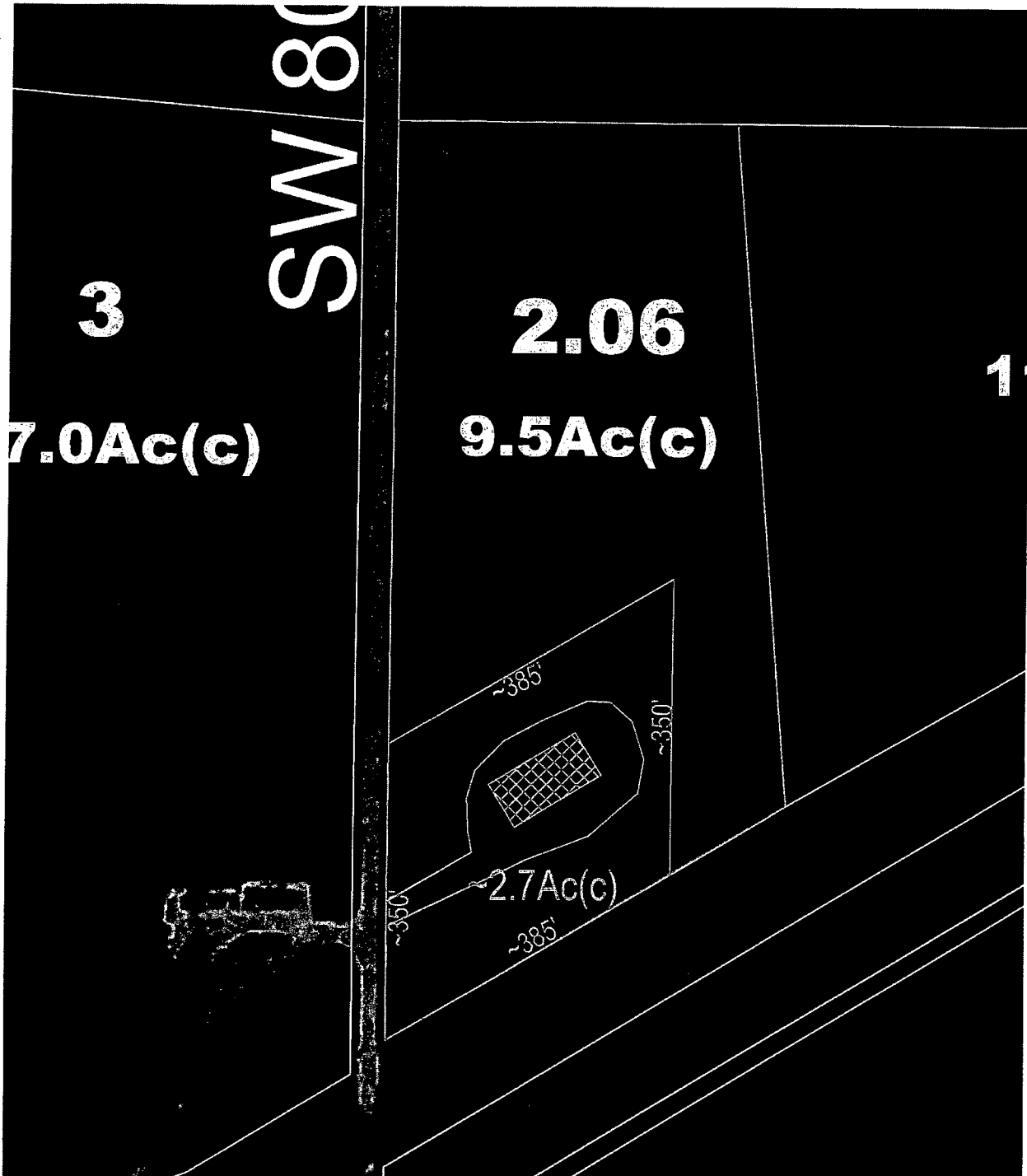

Crosby 466 SW 80 Ave 005-244-19.0-00-00-002.06-0

Section Lines & No.	Parcel Boundaries	Lot & Block Lines	Hydrology
City Boundaries	Parcel Number	Lot & Block Numbers	Landuse
Right-of-Way Lines	Parcel Text	Leaseholds	Soils

Kansas State Plane-South Zone, NAD 83  
 Scale: Compiled at 1"=400'  
 Plotted at N/A  
 Map current as of 2/7/2023  
 Map plotted on 2/9/23



Mapping  
 1400 Main St Rm 102 Great Bend, KS 67530  
 v. 620-793-1802 f. 620-793-1807  
 e. mapping@bartoncounty.org

Digital orthophoto by USDA, summer 2021, one meter pixel resolution  
 The contents of this map were developed for the use of various departments of Barton County. Property descriptions and other information as indicated on the map are unofficial and are not intended for conveyances. This map is not a legal survey. Barton County does not assume responsibility for any use of the map beyond the regulations or guidelines established for the county departments.

